

Reliable®

Model RFC30 (SIN RA0611)
Model RFC43 (SIN RA0612)
Model RFC49 (SIN RA0616)
Residential Flat Concealed
Sprinklers

A Residential Flat Concealed Sprinkler engineered for a minimum design density of 0.05 gpm/ft² with low GPM requirements.

Features

1. Very low water flow requirements.
2. ½" (13mm) Total adjustment.
3. Thread-On/Thread-Off or Push-On/Thread Off cover attachment option.
4. Smooth aesthetic ceiling profile.
5. Available in brass, chrome and black plated or painted finishes.

Listings & Approval

1. Listed by Underwriters Laboratories, and certified by UL for Canada (cULus)
2. NYC MEA 258-93-E

UL Listing Categories

Residential Automatic Sprinklers

UL Guide Number

VKKW

Product Description

Model RFC30, RFC43 and RFC49 Concealed Residential Sprinklers are fast response residential fusible solder link automatic sprinklers. Residential sprinklers differ from standard sprinklers primarily in their response time and water distribution patterns.

Model RFC30, RFC43 and RFC49 sprinklers discharge water in a hemispherical pattern below the sprinkler deflector. Residential distribution patterns are higher and generally contain a finer droplet size than standard sprinkler patterns.

The combination of speed of operation and high discharge pattern required for residential sprinklers has demonstrated, in fire testing, an ability for controlling residential fires, and thereby providing significant evacuation time for occupants.

The RFC30, RFC43 and RFC49 Sprinklers provide the best form of fire protection by combining an attractive appearance and ½" (13mm) of cover adjustment for ease of installation. The small diameter cover plate is easily and positively attached and blends into the ceiling, concealing



the most dependable fire protection available, an automatic sprinkler system.

The RFC30, RFC43 and RFC49 are UL Listed Residential Sprinklers to be installed in the residential portions of any occupancy in accordance with NFPA 13, 13R, & 13D.

The RFC30, RFC43 and RFC49 can reduce the need for precise cutting of drop nipples. The threaded cover plate assembly can be adjusted without tools to fit accurately against the ceiling. The fire protection system need not be shut down to adjust or remove the cover plate assembly.

Application and Installation

The RFC30, RFC43 and RFC49, for residential installations, use a 165°F (74°C) fusible solder link in a tuning fork style sprinkler frame with a drop-down deflector. This assembly is recessed into the ceiling and concealed by a flat cover plate. The cover plate is attached to the skirt, using 135°F (57°C) ordinary temperature classification solder. When the ceiling temperature rises, the solder holding the cover plate releases the cover allowing the deflector to drop into position and exposing the sprinkler inside to

ceiling temperature. The subsequent operation of the solder link opens the waterway and causes the deflector to drop into position to distribute the discharging water in a hemispherical pattern below the sprinkler deflector. Any adjustment of thread engagement between the cover plate and cup will assure that the drop-down deflector is properly located below the ceiling. The residential distribution pattern contains a finer droplet size than a standard sprinkler, and the pattern produces significantly higher wall wetting.

After a 2⁵/₈ inch diameter hole is cut in the ceiling, the sprinkler is to be installed with the Model FC Wrench. When installing a sprinkler, the wrench is first positioned into the sprinkler/cup assembly and around the hexagonal body of the sprinkler frame. The Wrench must bottom out against the cup in order to ensure proper, safe installation. The sprinkler is then tightened into the pipe fitting. When inserting or removing the wrench from the sprinkler/cup assembly, care should be taken to prevent damage to the sprinkler. **DO NOT WRENCH ON ANY OTHER PART**

OF THE SPRINKLER/CUP ASSEMBLY. MODEL RFC30, RFC43 AND RFC49 CONCEALED SPRINKLERS MUST BE INSTALLED ONLY WITH 135°F RATED COVERS.

Note: A leak tight 1/2" NPT (R1/2) sprinkler joint can be obtained with a torque of 8-18 ft-lbs (10,8 - 24,4 N-m). Do not tighten sprinklers over maximum recommended torque. It may cause leakage or impairment of the sprinklers.

Cover assemblies provide up to 1/2" (13mm) of adjustment. Turn the cover clockwise until the flange is in contact with the ceiling. For the push-on/thread-off option, the cover assembly is pushed onto the cup and final adjustment is made by turning the cover clockwise until the skirt flange makes full contact with the ceiling. Cover removal requires turning in the counter-clockwise direction.

In ceilings that have a plenum space above the sprinkler, the plenum space may have neutral or negative pressurization but must not be positively pressurized. Inspect all sprinklers after installation to ensure that the gap between the cover plate and ceiling and the 4 slots in the cup are all open and free from any air flow impediment.

Temperature Rating

Sprinkler	Cover Plate	Max. Ambient Temp.
165°F/74°C	135°F/57°C	100°F/38°C

Installation Data: RFC30 (SIN RA0611)

Thread Size inch (mm)	K Factor	Sprinkler Spacing ft. (m)	Maximum Distance to Wall ft. (m)	Minimum Distance between sprinklers ft. (m)	Minimum Required Sprinkler Discharge	
					Flow gpm (Lpm)	Press. psi (bar)
1/2" (15mm)	3.0	12 x 12 (3.6x3.6)	6 (1.83)	8 (2.43)	9 (34.1)	9.0 (0.62)
1/2" (15mm)	3.0	14 x 14 (4.3x4.3)	7 (2.13)	8 (2.43)	10 (37.8)	11 (0.76)

Note: 1 bar = 100 Kpa

Installation Data: RFC43 (SIN RA0612)

Thread Size inch (mm)	K Factor	Sprinkler Spacing ft. (m)	Maximum Distance to Wall ft. (m)	Minimum Distance between sprinklers ft. (m)	Minimum Required Sprinkler Discharge	
					Flow gpm (Lpm)	Press. psi (bar)
1/2" (15mm)	4.3	12 x 12 (3.6x3.6)	6 (1.83)	8 (2.43)	12 (45)	7.8 (0.54)
1/2" (15mm)	4.3	14 x 14 (4.3x4.3)	7 (2.13)	8 (2.43)	13 (49)	9.1 (0.63)
1/2" (15mm)	4.3	16 x 16 (4.9x4.9)	8 (2.43)	8 (2.43)	13 (49)	9.1 (0.63)
1/2" (15mm)	4.3	18 x 18 (5.5x5.5)	9 (2.74)	8 (2.43)	18 (68)	17.5 (1.21)
1/2" (15mm)	4.3	20 x 20 (6.0x6.0)	10 (3.05)	8 (2.43)	21 (79)	23.8 (1.64)

Note: 1 bar = 100 Kpa

Installation Data: RFC49 (RA0616)

Thread Size inch (mm)	K Factor	Sprinkler Spacing ft. (m)	Maximum Distance to Wall ft. (m)	Minimum Distance between sprinklers ft. (m)	Minimum Required Sprinkler Discharge	
					Flow gpm (Lpm)	Press. psi (bar)
1/2" (15mm)	4.9	12 x 12 (3.6x3.6)	6 (1.83)	8 (2.43)	13 (49)	7.0 (0.48)
1/2" (15mm)	4.9	14 x 14 (4.3x4.3)	7 (2.13)	8 (2.43)	13 (49)	7.0 (0.48)
1/2" (15mm)	4.9	16 x 16 (4.9x4.9)	8 (2.43)	8 (2.43)	13 (49)	7.0 (0.48)
1/2" (15mm)	4.9	18 x 18 (5.5x5.5)	9 (2.74)	8 (2.43)	17 (64.3)	12.0 (0.83)
1/2" (15mm)	4.9	20 x 20 (6.0x6.0)	10 (3.05)	8 (2.43)	20 (75.7)	16.7 (1.14)

Note: 1 bar = 100 Kpa

FOR SLOPED CEILING APPLICATIONS SEE RASCO BULLETIN 035.

Maintenance

Model RFC30, RFC43 and RFC49 Concealed Sprinklers should be inspected quarterly and the sprinkler system maintained in accordance with NFPA 25. Do not clean sprinklers with soap and water, ammonia or any other cleaning fluids. Remove dust by using a soft brush or gentle vacuuming. Remove any sprinkler cover plate assembly which has been painted (other than factory applied) or damaged in any way. A stock of spare sprinklers should be maintained to allow quick replacement of damaged or operated sprinklers. Prior to installation, sprinklers should be maintained in the original cartons and packaging until used to minimize the potential for damage to sprinklers that would cause improper operation or non-operation.

Model RFC30, RFC43 and RFC49 Residential Concealed Sprinkler Specification

Sprinklers shall be cULus Listed low flow residential concealed sprinklers with drop-down deflector and adjustable flat cover plate engineered for a minimum design density of 0.05 gpm/ft². Sprinkler frame and deflector shall be of bronze frame construction having a 1/2" NPT thread. Thermal element shall consist of an approved black-painted beryllium-nickel fusible solder link with symmetric lever mechanism, maintaining a Teflon-coated Belleville spring washer and machined brass cap water seal assembly containing no plastic parts. Sprinkler K-factor shall be nominal 3.0 (44), 4.3 (62.4), and 4.91 (70) having a 5/16", 3/8" and 7/16" orifice. Temperature rating shall be Ordinary 165°F (74°C); cover plate temperature rating to be 135°F (57°C). Cover plate assembly shall

consist of a brass cover plate and copper alloy retainer flange allowing a 1/2" cover plate adjustment. Any secure engagement between the cover plate and the cup will assure that the drop-down deflector is properly located below the ceiling. A plastic protective cap shall be provided and factory installed inside the sprinkler cup to protect the drop-down sprinkler deflector from damage, which could occur during construction before the cover plate is installed. Standard cover finish: [Chrome] [White] [Specialty – specify]. Residential concealed sprinklers shall be Reliable Model RFC30, SIN RA0611 (Bulletin 006), Model RFC43, SIN RA0612 (Bulletin 006) or Model RFC49, SIN RA0616 (Bulletin 006).

Ordering Information Specify:

1. Sprinkler Model
2. Cover Plate Finish
3. Thread-On or Push-On Feature

Cover Plate Finishes (1)

Standard Finishes
Chrome White
Special Application Finishes
Bright Brass Black Plating Black Paint Off White Satin Chrome

(1) Other colors and finishes available. Consult factory for details. **Note:** Paint or any other coatings applied over the factory finish will void all approvals and warranties.

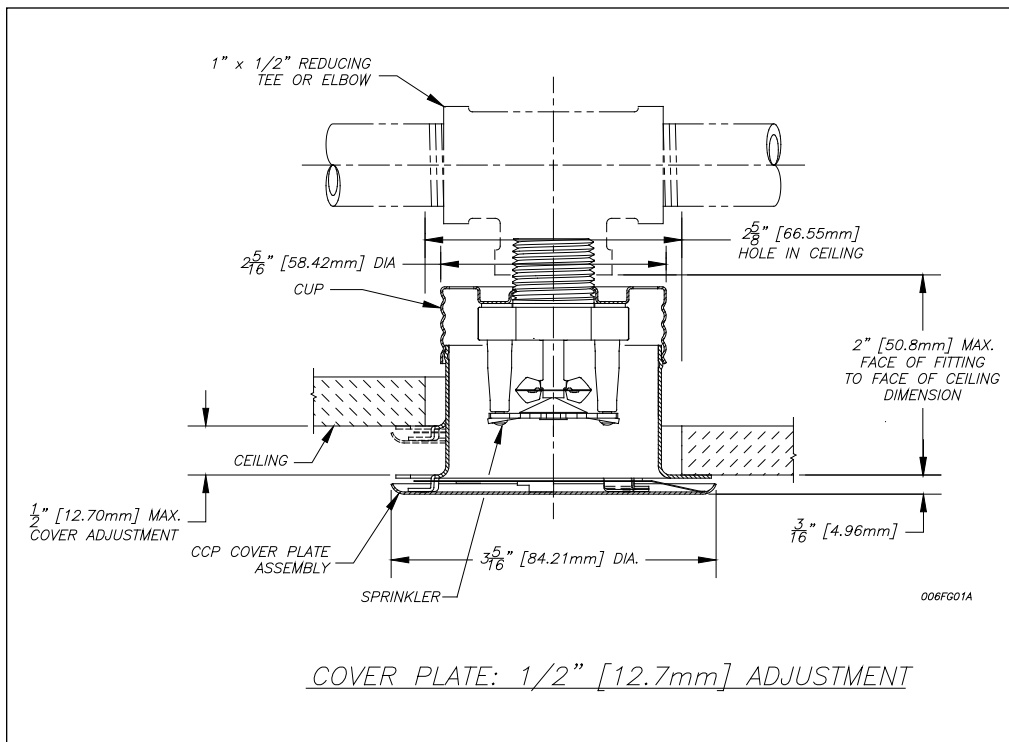

Reliable...For Complete Protection

Reliable offers a wide selection of sprinkler components. Following are some of the many precision-made Reliable products that guard life and property from fire around the clock.

- Automatic sprinklers
- Flush automatic sprinklers
- Recessed automatic sprinklers
- Concealed automatic sprinklers
- Adjustable automatic sprinklers
- Dry automatic sprinklers
- Intermediate level sprinklers
- Open sprinklers
- Spray nozzles
- Alarm valves
- Retarding chambers
- Dry pipe valves
- Accelerators for dry pipe valves
- Mechanical sprinkler alarms
- Electrical sprinkler alarm switches
- Water flow detectors
- Deluge valves
- Detector check valves
- Check valves
- Electrical system
- Sprinkler emergency cabinets
- Sprinkler wrenches
- Sprinkler escutcheons and guards
- Inspectors test connections
- Sight drains
- Ball drips and drum drips
- Control valve seals
- Air maintenance devices
- Air compressors
- Pressure gauges/identification signs
- Fire department connection

The equipment presented in this bulletin is to be installed in accordance with the latest published Standards of the National Fire Protection Association, Factory Mutual Research Corporation, or other similar organizations and also with the provisions of governmental codes or ordinances whenever applicable. Products manufactured and distributed by Reliable have been protecting life and property for over 90 years, and are installed and serviced by the most highly qualified and reputable sprinkler contractors located throughout the United States, Canada and foreign countries.

Manufactured by

Reliable[®]

The Reliable Automatic Sprinkler Co., Inc.
(800) 431-1588 Sales Offices
(800) 848-6051 Sales Fax
(914) 829-2042 Corporate Offices
www.reliablesprinkler.com Internet Address



Revision lines indicate updated or new data.

EG. Printed in U.S.A 02/11 P/N 9999970261